

ELECTRIC WALKIE PALLET JACK



4500 LBS.

SPECIFICATIONS



8HBW23

CLASS
3

ELECTRIC PALLET JACKS | STACKERS | TOW TRACTORS

ToyotaForklift.com

ELECTRIC WALKIE

CAPACITY
4500 LBS.

FORK LENGTH
32 – 60 IN.

FORK WIDTH
6.76 IN.

INDUSTRIES



Beverage



Cold Storage



Distribution



Food Storage



General
Warehousing



Retail

STANDARD FEATURES

PERFORMANCE

- 24-Volt electrical system
- AC drive motor with thermal protection & current limiting
- Class “F” motor insulation
- Transistor drive control system
- Controller area network (CAN-bus) communication
- Regenerative plugging
- Contactor-less drive controls
- Electronic touchpad, keyless entry system with password protection
- Programmable performance for up to 10 operators
- Electronic raise & lower controls in operator handle
- Programmable auto-off system
- Error indicator with self-diagnostics
- Fault code memory with hour meter reading
- Hour meter indicator
- Programmable service indicator
- Battery discharge indicator with lift interrupt
- Anti-rollback system
- Fused control & power circuits
- IP65-rated electrical system
- Fork height travel interlock

BODY/EXTERIOR DESIGN

- Box rail fork construction
- Tapered fork tips with pallet entry slides
- Polyethylene stability wear pads (reversible)
- Teflon[®]-coated PolyLube™ bushings
- Chrome-plated lift cylinder, 2" dia.
- Rubber drive tire, 10" dia. x 5" width
- Sealed-bearing polyurethane load wheels, 3.25" dia. x 4.5" width
- Battery compartment 26.5" x 7.8" x open height
- SB-175 battery connector (red)
- High-strength service cover with pen/pencil storage tray
- Tool-free cover removal
- Steel fixed pull rods
- Electric horn
- Stainless steel lift linkage pins

OPERABILITY & ERGONOMICS

- Multifunction control handle with ergonomically angled handgrips
- Fingertip control of all functions
- Directional thumb controls
- Programmable neutral speed reduction
- Direction reverse switch on control handle
- Turtle torque control
- Spring-loaded control handle
- “Pinwheel” capability for right angle stacking
- Electric disc brake
- Emergency power disconnect
- Battery disconnect handle
- Electronic brake release switch
- Click to creep button

OPTIONAL EQUIPMENT

- 48"-high load backrest
- 60"-high load backrest
- 72"-high load backrest
- Battery compartment 26.5" x 9" x open height
- Battery/charger pack (24V) flooded lead-acid (175 Ah)
- Battery/charger pack (24V) maintenance-free (195 Ah)
- Polyurethane torsion block casters
- Crowned poly drive tire
- Grip rubber drive tire (maxmatic tread)
- Polyurethane drive tire
- Cold storage conditioning
- Galvanized chassis
- UL-approved model type “E”
- UL-approved model type “EE”
- Charger pack (less batteries)
- GNB maintenance-free battery/charger pack (24V – 195 Ah)
- NexSys[®] maintenance-free battery/charger pack
- Key switch
- 3" lowered fork height (reduces capacity to 3000 lbs.)
- Convert load wheels to greasable-bearing
- Forward/reverse travel alarm
- Reflective decals
- Magnetic base shrinkwrap holder
- Integrated Fork Scale (Legal for Trade)
- Integrated Fork Scale (Non-Legal for Trade)
- Bluetooth Data Transfer for Integrated Fork Scale
- Cold Storage for Integrated Fork Scale
- RS232 Serial Connector for Integrated Fork Scale
- Onboard charger
- Accessory bar options
- Operator fan
- Magnetic storage tote
- LED work light

Please contact your local, authorized Toyota Dealer for a complete list of available options.

TRUCK SPECIFICATIONS

MODEL NUMBERS

| EXTERIOR DIMENSIONS ¹ | | | 8HBW23 | | | | | | |
|--------------------------------------|---------|---------|-------------|-------------|-------------|-------------|-------------|-------------|-------------|
| Capacity | | lb (kg) | 4500 (2040) | | | | | | |
| A Fork Length (actual) | | in (mm) | 29.5 (750) | 33.5 (851) | 39.5 (1004) | 43.5 (1105) | 45.4 (1152) | 51.5 (1308) | 57.5 (1461) |
| B Overall Length | | in (mm) | 53.4 (1356) | 57.4 (1457) | 63.4 (1610) | 67.4 (1711) | 69.2 (1758) | 75.4 (1914) | 81.4 (2067) |
| C Wheelbase | Lowered | in (mm) | 40.2 (1022) | 44.2 (1123) | 50.2 (1276) | 54.2 (1377) | 56.1 (1424) | 62.2 (1580) | 68.2 (1733) |
| | Raised | in (mm) | 37.2 (944) | 41.1 (1045) | 47.1 (1198) | 51.1 (1299) | 53 (1346) | 59.1 (1502) | 65.2 (1655) |
| D Load Wheel Location | Lowered | in (mm) | 24.1 (611) | 28 (712) | 34.1 (865) | 38 (966) | 39.9 (1013) | 46 (1169) | 52 (1322) |
| | Raised | in (mm) | 20.9 (531) | 24.9 (632) | 30.9 (785) | 34.9 (886) | 36.7 (933) | 42.9 (1089) | 48.9 (1242) |
| E Turning Radius (raised) | | in (mm) | 44.8 (1138) | 48.8 (1239) | 54.8 (1392) | 58.8 (1493) | 60.6 (1540) | 66.8 (1696) | 72.8 (1849) |
| F Overall Width | | in (mm) | 28 (711) | | | | | | |
| G Power Unit Height (lowered) | | in (mm) | 32.7 (831) | | | | | | |
| H Control Handle Height | Lowered | in (mm) | 23.6 (600) | | | | | | |
| | Raised | in (mm) | 47.2 (1200) | | | | | | |
| J Bumper to Drive Tire Center | | in (mm) | 7.7 (195) | | | | | | |
| K Bumper Underclearance | | in (mm) | 3.0 (75) | | | | | | |
| L Fork Width | | in (mm) | 6.76 (172) | | | | | | |
| M Fork Overall Width (actual) | | in (mm) | 26.6 (675) | | | | | | |
| N Head Length | | in (mm) | 23.9 (606) | | | | | | |
| O Fork Down Height | | in (mm) | 3.25 (83) | | | | | | |
| P Elevated Height | | in (mm) | 9.1 (231) | | | | | | |
| Q Lift | | in (mm) | 5.6 (141) | | | | | | |

| PERFORMANCE DATA | | | 8HBW23 | | | | | | |
|------------------|-----------|------------|-----------|--|--|--|--|--|--|
| Travel Speed | Full Load | mph (km/h) | 3.6 (5.8) | | | | | | |
| | No Load | mph (km/h) | 3.6 (5.8) | | | | | | |
| Gradeability | Full Load | % | 10 | | | | | | |
| | No Load | % | 10 | | | | | | |

| TIRES | | | 8HBW23 | | | | | | |
|-------|-------------|--|--------------|--|--|--|--|--|--|
| Type | Drive Tire | | Rubber | | | | | | |
| | Load Wheels | | Polyurethane | | | | | | |

| POWER SYSTEM | | | 8HBW23 | | | | | | |
|---|----------|----|--------------|--|--|--|--|--|--|
| Battery | | V | 24 | | | | | | |
| Max. Amp Hr. | | Ah | 330 | | | | | | |
| Battery Connector / Color | | | SB-175 / Red | | | | | | |
| Battery Connector Cable Location | | | B | | | | | | |
| Battery Connector Cable Length | | in | 18 | | | | | | |
| Battery Weight Maximum | | lb | 660 | | | | | | |
| Battery Weight Minimum | | lb | 200 | | | | | | |
| Battery Compartment (L x W) – Open Height | Standard | in | 26.5 x 7.8 | | | | | | |
| | Optional | in | 26.5 x 9 | | | | | | |

| AISLE REQUIREMENT - RIGHT ANGLE STACK ² | | | 8HBW23 | | | | | | | |
|--|-----------|---------|-----------------------------------|-------------|-------------|-------------|-------------|-------------|-------------|----|
| | | | Load Length (Nominal Fork Length) | | | | | | | |
| | | | in (mm) | 32 | 36 | 42 | 46 | 48 | 54 | 60 |
| Load Width | 40 (1016) | in (mm) | 69.3 (1760) | 73.3 (1862) | 79.3 (2014) | 83.3 (2116) | 85.3 (2167) | 91.3 (2319) | 97.3 (2471) | |
| | 44 (1118) | in (mm) | 71.2 (1808) | 75.2 (1910) | 81.2 (2062) | 85.2 (2164) | 87.2 (2215) | 93.5 (2376) | 99.2 (2520) | |

EXTERIOR DIMENSIONS

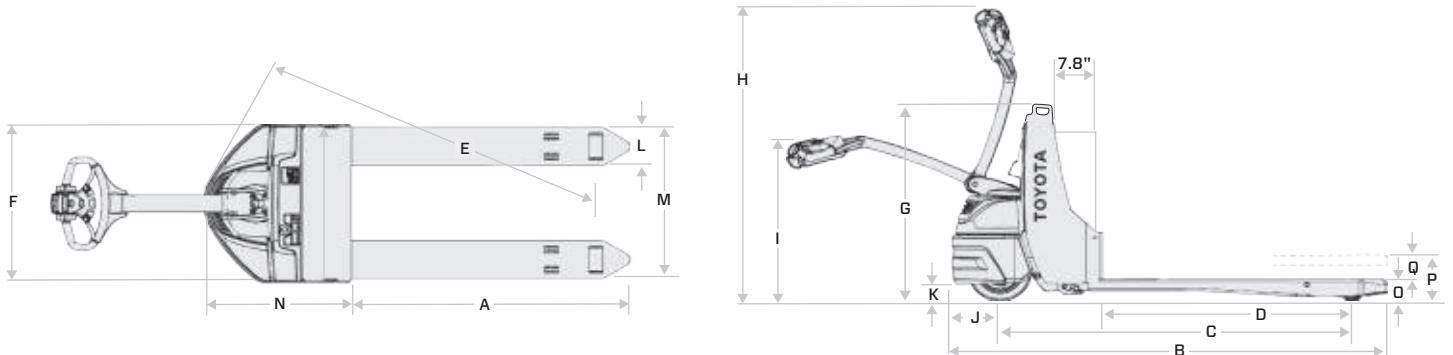

1 Exterior dimensions have been given for a standard model with a 7.8" battery compartment.
 2 Minimum Aisle Width for Right-Angle Stacking: Aisle widths have been given for a standard model with 7.8" battery compartment. Add a minimum of 12" for maneuverability.



“THE NAME ON MY SHIRT
SAYS TOYOTA,
BUT I WORK
FOR YOU.”

Alan – 360 Technician, Atlas Toyota Material Handling, Chicago, IL



HELP IS ALWAYS HERE WITH TOYOTA 360 SUPPORT.

The industry’s best and most comprehensive dealer network quickly delivers Toyota Certified Technicians to your work site. These specially trained technicians can also help assess your warehouse and facility needs to recommend the right equipment for the job. And with the largest fleet of used and rental material handling products, Toyota 360 keeps your business running at full speed.

ToyotaForklift.com/360-Support



YOUR BUSINESS IS RIDING ON IT.

Some product features described herein are optional. Please consult your dealer for specifications. Details of specifications and equipment are based on information available at time of printing and may change without notice.

