

600AJN

ARTICULATED BOOM LIFT



- Fully electric, with dual fuel regeneration for extended duty cycles per charge
- Zero emissions with quiet operation for indoor use
- Can be fully recharged in 6 hours
- Gravity-descent design to maximize efficiency and duty cycle
- Zero tailswing and zero steer for maximum maneuverability

 **snorkel**[™]
www.snorkellifts.com

ARTICULATED BOOM LIFT

600AJN

DIMENSIONS	600AJN*
Max. working height	66 ft 2 in
Max. platform height	60 ft 2 in
Max. horizontal reach	44 ft 6 in
Clearance height at max. outreach	21 ft 6 in
Platform size	6 ft x 3 ft
Overall width (A)	7 ft
Overall length (B)	30 ft 4 in
Stowed height (C)	7 ft 6 in
Ground clearance	9.75 in

PERFORMANCE	
Platform capacity (SWL)	600 lbs
Platform capacity (restricted)	1,000 lbs
Max. drive height	60 ft 2 in
Max. wind speed	28 mph
Max. drive speed (stowed)	4.25 mph
Max. drive speed (elevated)	0.6 mph
Jib length	5 ft 5 in
Jib working arc	75°
Platform rotation	180°
Superstructure rotation	360° continuous
Tailswing	0 in
Foreswing	12 in
Raise/lower time	80/80 sec
Gradeability	45%
Inside turning radius	5 ft 6 in
Outside turning radius	11 ft
Oscillating axle	8 in
Tires	33 x 10-24 foam filled
Controls	fully proportional
Drive system	48V electric, 4-wheel drive

POWER	
Power source	48V DC batteries (8 x 6v) Kubota WG752 17.2hp dual fuel (gasoline/LPG) Tier 3 powering 6kW DC generator

WEIGHT	
Weight	25,000 lbs

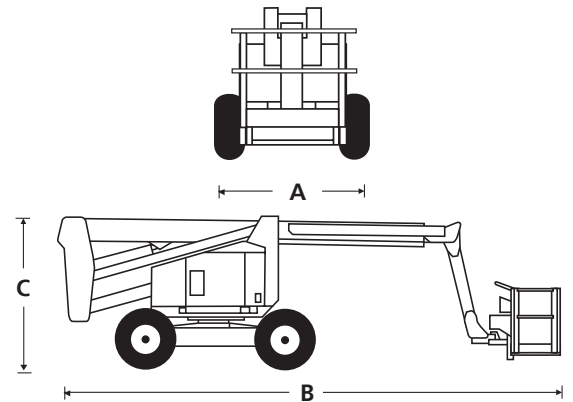

STANDARD FEATURES

- Zero tailswing
- 4 steering modes - 2-wheel, 4-wheel, crab and pivot
- Snorkel Guard™ secondary guarding system
- Proportional controls
- Oscillating axle
- 6' tri-entry platform with high grip aluminum floor
- Foam filled tires
- Power line to platform
- Hour meter & on-board diagnostics display
- Tilt alarm
- Horn
- Battery charge indicator
- Drive motion alarm
- Flashing amber light
- 2 year parts & labor, 5 year structural warranty
- ANSI compliant

OPTIONS

- Special paint colors
- Airline to platform
- Non-marking tires
- 12V cooling fans in platform
- Mesh platform guarding
- Tool tray
- Folding workbench in platform
- Aircraft package
- Deluxe aircraft package
- Cold weather package
- Extreme cold weather package
- Extreme environment package
- Light package
- Utility package
- Glazier package
- Pipe rack
- Generator package 2.5kW
- Generator package 6kW
- Environmental hydraulic oil
- Snorkel OnSite™ telematics

WORKING ENVELOPE

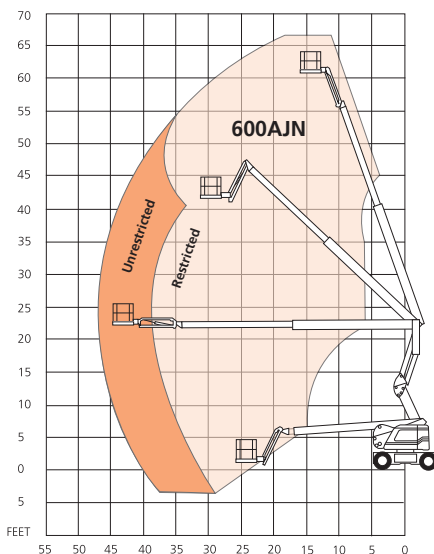

ANSI Specification ©Snorkel 2021 Specifications subject to change without notice. Photos and diagrams in this brochure are for promotional purposes only. Refer to appropriate Snorkel operators manual for detailed instructions on the proper use and maintenance. * Preliminary specifications – confirm at time of ordering.

snorkel www.snorkellifts.com

P.O. Box 1160
 St. Joseph, MO 64502-1160, USA
 Tel: 1 (785) 989-3000
 Toll-free: 1 (800) 255-0317
 Sales Fax: 1 (785) 989-3070
 Parts Fax: 1 (785) 989-3077