

# MB20J/MB26J

## MAST BOOM LIFTS

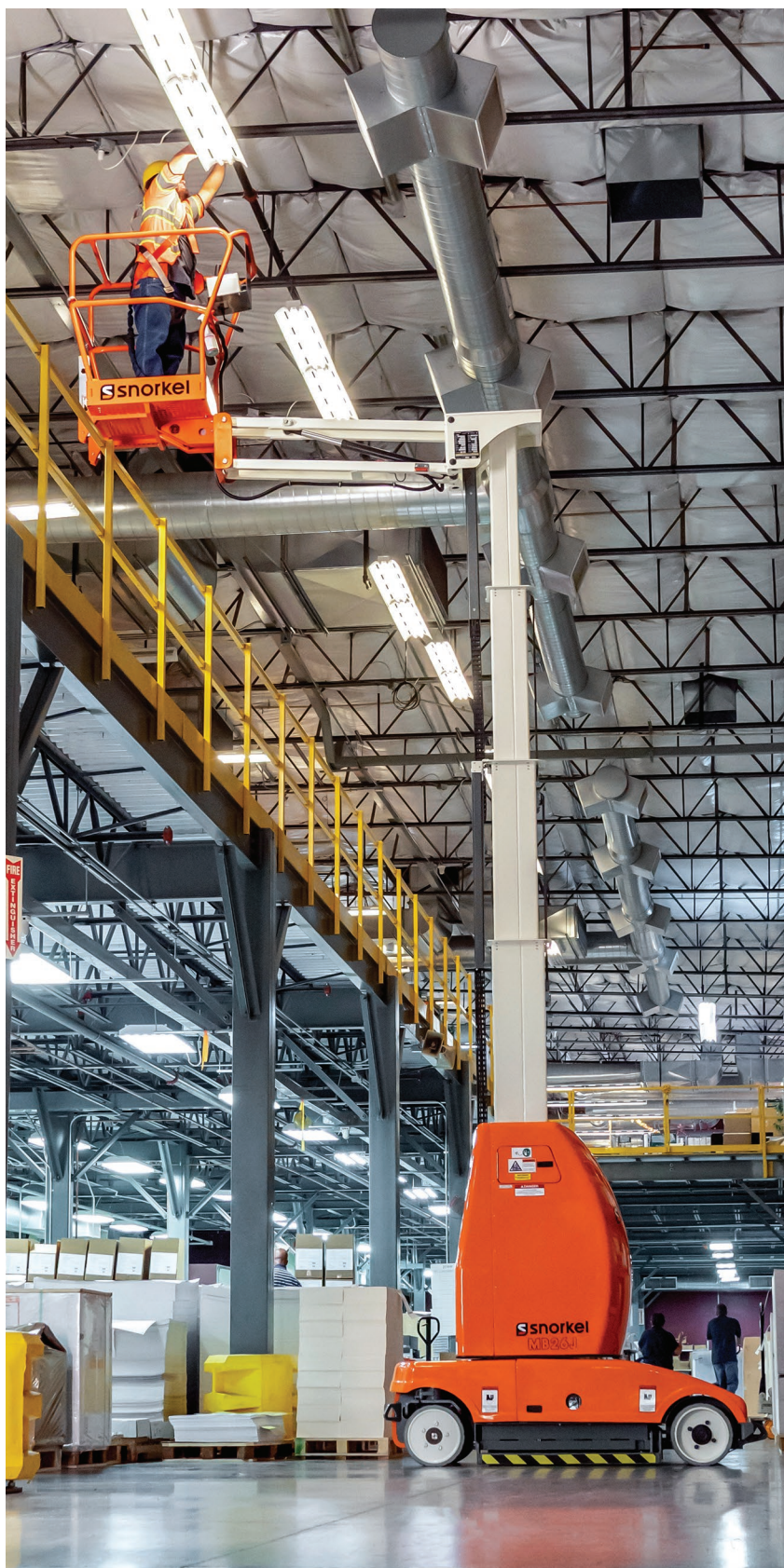

- Versatile electric mast booms
- Ultra-narrow for use in confined spaces
- Superb working envelope including "up & over" capabilities
- Simple to operate and maintain
- Ideal for retail & warehouse applications

 **snorkel**™  
[www.snorkellifts.com](http://www.snorkellifts.com)

# MAST BOOM LIFTS

# MB20J/MB26J

DIMENSIONS	MB20J	MB26J
Max. working height	26 ft	31 ft 6 in
Max. platform height	20 ft	25 ft 6 in
Max. horizontal reach	8 ft 6 in	9 ft 10 in
Platform size	30 in x 28 in	30 in x 28 in
Overall width (A)	32 in	39 in
Overall length (C)	7 ft 11 in	9 ft 2 in
Stowed height (B)	6 ft 6 in	6 ft 6 in
Ground clearance	4 in	4 in

PERFORMANCE		
Platform capacity (SWL)	475 lbs	475 lbs
Max. wind speed	28 mph	28 mph
Max. drive height	20 ft	25 ft 4 in
Max. drive speed (stowed)	2.0 mph	2.0 mph
Max. drive speed (elevated)	0.3 mph	0.3 mph
Jib length	3 ft 4 in	4 ft 7 in
Jib arc	130°	130°
Mast rotation (non-continuous)	360°	360°
Raise/lower time	54/26 sec	56/27 sec
Gradeability	25%	25%
Inside turning radius	11 in	11 in
Outside turning radius	6 ft	6 ft 10 in
Tires	13.5 x 4 non-marking rubber	
Controls	proportional controls	
Drive system	electro/hydraulic	

POWER	
Power source	4 x 6V 375 Ah batteries
Battery charger	self-seeking automatic battery charger

WEIGHT		
Weight	6,640 lbs	7,000 lbs

## WORKING ENVELOPE

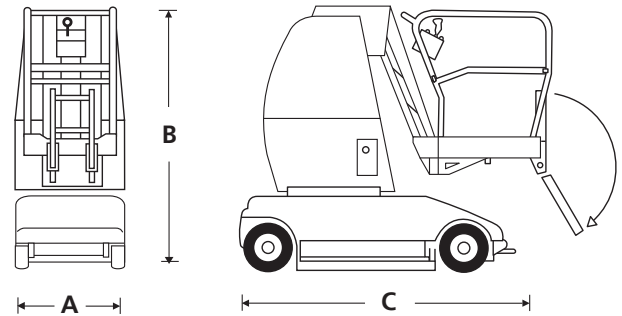
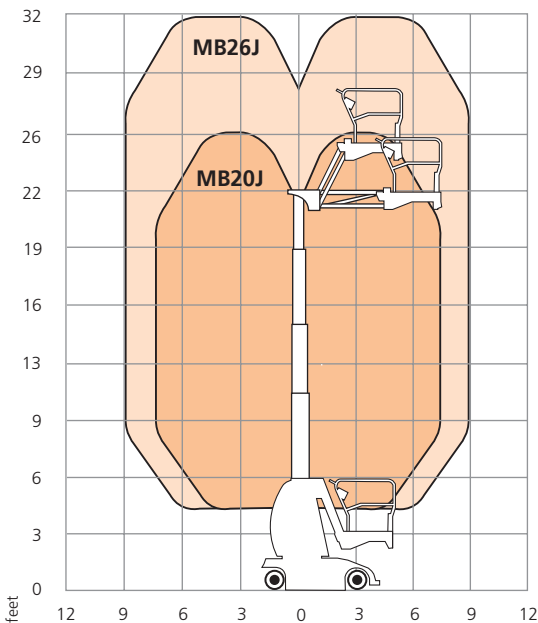

## STANDARD FEATURES

- Ultra-tight inside turning radius
- Proportional controls
- Tilt alarm
- Non-marking tires
- 2 persons indoor
- 1 person outdoor
- Self-seeking automatic battery charger
- Automatic battery fill
- Power line to platform
- Hour meter & on-board diagnostics display
- Hydraulic pothole protection system
- 2 year parts & labor, 5 year structural warranty
- ANSI compliant

## OPTIONS

- Special paint colors
- Flashing amber light
- Environmental hydraulic oil
- Snorkel OnSite™ telematics

**snorkel** [www.snorkellifts.com](http://www.snorkellifts.com)

P.O. Box 1160  
 St. Joseph, MO 64502-1160, USA  
 Tel: 1 (785) 989-3000  
 Toll-free: 1 (800) 255-0317  
 Fax: 1 (785) 989-3070  
 Email: sales.usa@snorkellifts.com