

S277ORTE/S337ORTE/S397ORTE

ELECTRIC COMPACT ROUGH TERRAIN SCISSOR LIFTS



- Zero emission electric compact rough terrain scissor lift with lithium-ion batteries
- Excellent rough terrain performance
- Suitable for interior and exterior use
- Roll-out deck extension for extra reach
- Fully charged in 5-8 hours



snorkelTM
www.snorkellifts.com

ELECTRIC COMPACT ROUGH TERRAIN SCISSOR LIFTS

S277ORTE/ S337ORTE/S397ORTE

DIMENSIONS	S277ORTE*	S337ORTE*	S397ORTE*
Max. working height	33 ft	39 ft	45 ft
Max. platform height (A)	27 ft	33 ft	39 ft
Platform size (stowed) (B)	5 ft 2 in x 9 ft 8 in		
Platform size (extended) (C)	5 ft 2 in x 13 ft 1 in		
Extension deck length	4 ft	4 ft	4 ft
Overall width (D)	5 ft 10 in	5 ft 10 in	5 ft 10 in
Overall length (E)	11 ft 3 in	11 ft 3 in	11 ft 3 in
Stowed height (F)	8 ft 7 in	9 ft	9 ft 8 in
Min. height (guardrails folded)	6 ft	6 ft 6 in	7 ft
Ground clearance	13 in	13 in	13 in

PERFORMANCE	S277ORTE*	S337ORTE*	S397ORTE*
Platform capacity (SWL)	1,250 lbs	1,000 lbs	771 lbs
Max. drive height	27 ft	33 ft	39 ft
Max. wind speed	28 mph	28 mph	28 mph
Max. drive speed (stowed)	2.8 mph	2.8 mph	2.8 mph
Max. drive speed (elevated)	0.3 mph	0.3 mph	0.3 mph
Raise/lower time	26/30 sec	50/60 sec	50/60 sec
Gradeability	35%	35%	35%
Max. stabilizer levelling, front to rear	6°	6°	6°
Max. stabilizer levelling, side to side	10°	10°	10°
Inside turning radius	8 ft 10 in	8 ft 10 in	8 ft 10 in
Outside turning radius	16 ft 3 in	16 ft 3 in	16 ft 3 in
Tires	27 x 10.5 – 15 foam filled non-marking		
Controls	proportional joystick		
Drive system	4-wheel drive		

POWER	S277ORTE*	S337ORTE*	S397ORTE*
Power source	222 Ah Li-ion batteries with integrated BMS		
Operating temperature	(-)77°F to (+)140°F		
Charger	high frequency smart on-board 50A battery charger		

MOTOR	S277ORTE*	S337ORTE*	S397ORTE*
Motor	AC electric motor		

WEIGHT	S277ORTE*	S337ORTE*	S397ORTE*
Weight	6,172 lbs	7,980 lbs	8,355 lbs

TURNING RADIUS

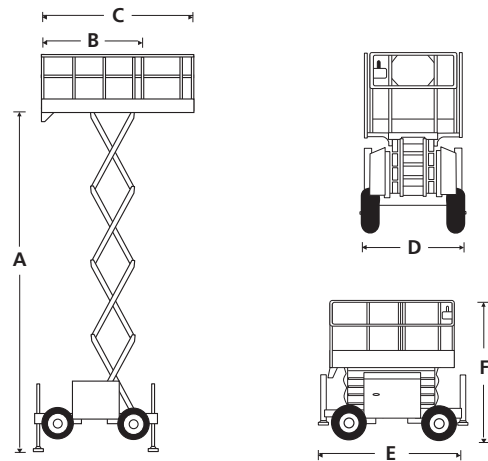
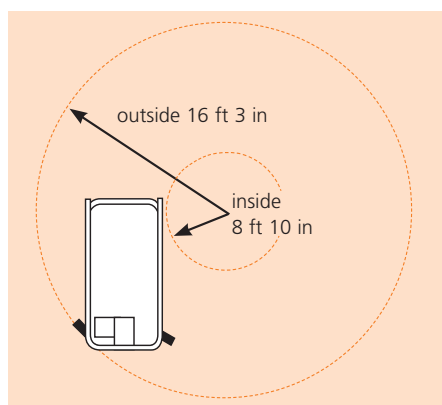

STANDARD FEATURES

- Two lithium-ion battery systems 222Ah
- 4-wheel drive
- Roll-out deck extension
- 4 hydraulic stabilizers with automatic levelling
- Non-marking foam filled tires
- Proportional controls
- Power line to platform
- Platform overload system
- Drive motion alarm
- Descent alarm
- Fold-down guardrails
- Flashing amber lights (2)
- Oscillating axle
- Hour meter & on-board diagnostics display
- Manual lowering valve
- Dual lanyard attachment points
- 2000 charging cycles/2 year** lithium battery warranty
- 2 year parts & labor, 5 year structural warranty
- ANSI compliant

OPTIONS

- Special paint colors
- Additional 111Ah battery system
- Hydraulic generator 110V 2kW
- Nylon spreader pads (set of 4)
- Environmental hydraulic oil
- Snorkel OnSite™ telematics

snorkel www.snorkellifts.com

P.O. Box 1160
St. Joseph, MO 64502-1160, USA
Tel: 1 (785) 989-3000
Toll-free: 1 (800) 255-0317
Fax: 1 (785) 989-3070
Email: sales.usa@snorkellifts.com