

# ML12M/ML16M/ML20M

## MATERIAL LIFTS



- A high specification material lift, with best-in-class load capacity
- Narrow design with reduced height mast to easily pass through a single doorway
- Robust and reliable
- Features a dual-handle, shift-on-the-fly, two-speed winch for improved productivity

 **snorkel**™  
[www.snorkellifts.com](http://www.snorkellifts.com)

# MATERIAL LIFTS ML12M/ML16M/ML20M

DIMENSIONS	ML12M	ML16M	ML20M
Lift height – forks up	12 ft 6.5 in	16 ft 1 in	19 ft 8 in
Lift height – forks down	10 ft 10 in	14 ft 5 in	17 ft 11 in
Stowed width <b>(A)</b>	30.5 in	30.5 in	30.5 in
Stabilizer width <b>(B)</b>	64 in	64 in	64 in
Stowed length <b>(C)</b>	33 in	34.5 in	36 in
Operating length	5 ft 8 in	6 ft 1 in	6 ft 11 in
Stowed height <b>(D)</b>	5 ft 3 in	5 ft 3 in	5 ft 3 in
Fork width (outside)	23 in	23 in	23 in
Fork length <b>(E)</b>	30 in	30 in	30 in
Ground clearance	2.5 in	2.5 in	2.5 in

PERFORMANCE	ML12M	ML16M	ML20M
Max. load capacity (14 in. load center)	700 lbs	650 lbs	600 lbs
Max. load capacity (24 in. load center)	440 lbs	430 lbs	400 lbs
Max. load capacity (42 in. load center)	185 lbs	175 lbs	200 lbs
Min. load height	6 in	6 in	6 in
Winch (high speed)		4 cranks/ft	
Winch (low speed)		15 cranks/ft	

WEIGHT	ML12M	ML16M	ML20M
Weight	265 lbs	298 lbs	332 lbs

## LOAD CAPACITY - STANDARD FORKS

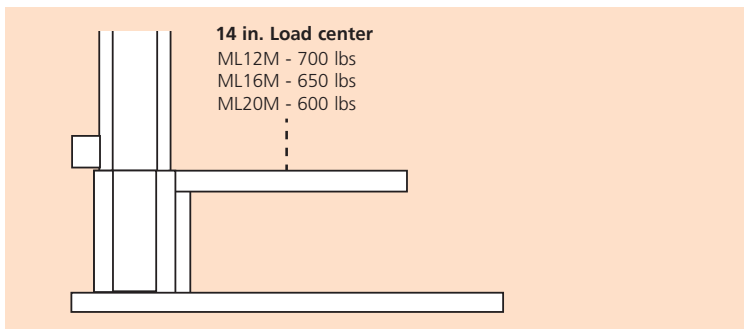

## LOAD CAPACITY - EXTENDED FORKS

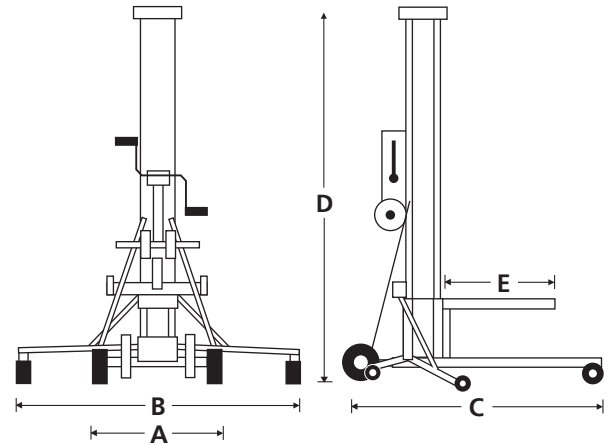
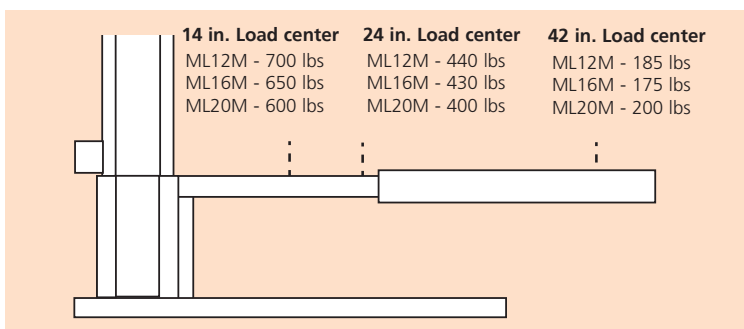

## STANDARD FEATURES

- Stabilizers with non-marking swivel casters (ML20M)
- Non-marking transport/loading wheels
- Cable guard
- Mast brake
- Dual-handle, two-speed shift-on-the-fly winch
- Metal cable pulleys with sealed bearings
- Heavy-gauge aluminum extrusions
- Heavy duty, non-marking casters
- Crane attachment point
- 2 year parts & labor, 5 year structural warranty
- ANSI compliant

## OPTIONS

- Special paint colors
- Adjustable forks
- Fork extensions
- Boom
- Pipe cradle
- Load platform
- Stabilizers with non-marking swivel casters (ML12M & ML16M)
- Smart latch

**snorkel**

www.snorkellifts.com

P.O. Box 1160  
 St. Joseph, MO 64502-1160, USA  
 Tel: 1 (785) 989-3000  
 Toll-free: 1 (800) 255-0317  
 Fax: 1 (785) 989-3070  
 Email: sales.usa@snorkellifts.com